



I N T E R N A T I O N A L





I N T E R N A T I O N A L



MILCO MANUFACTURING INC

A TRUE MANUFACTURING PHILOSOPHY

- Established 1950
- Million dollar investment 2018

OUR CORE BUSINESS

- Modular and conventional weld guns
- Perishable components
- Pneumatic cylinders
- Servo gun technology
- Nut and stud welding & assembly machines
- Robot associated services

WELFORM ELECTRODES INC

Our product line includes:

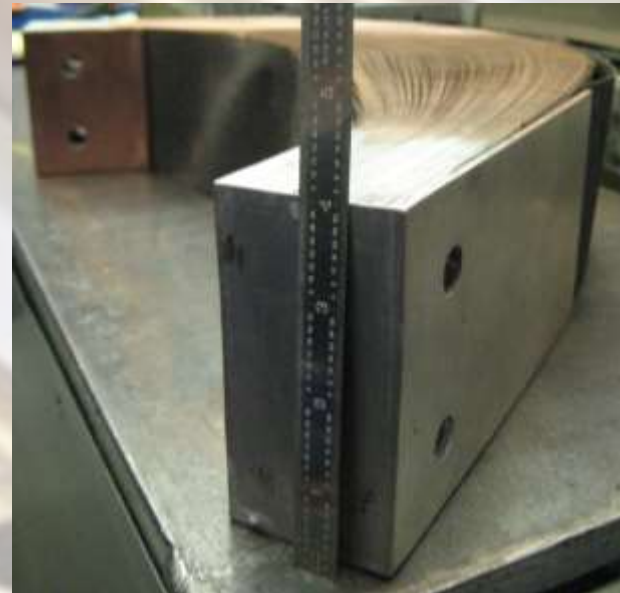

GLOBAL REACH

DSC
MECHATRONICS

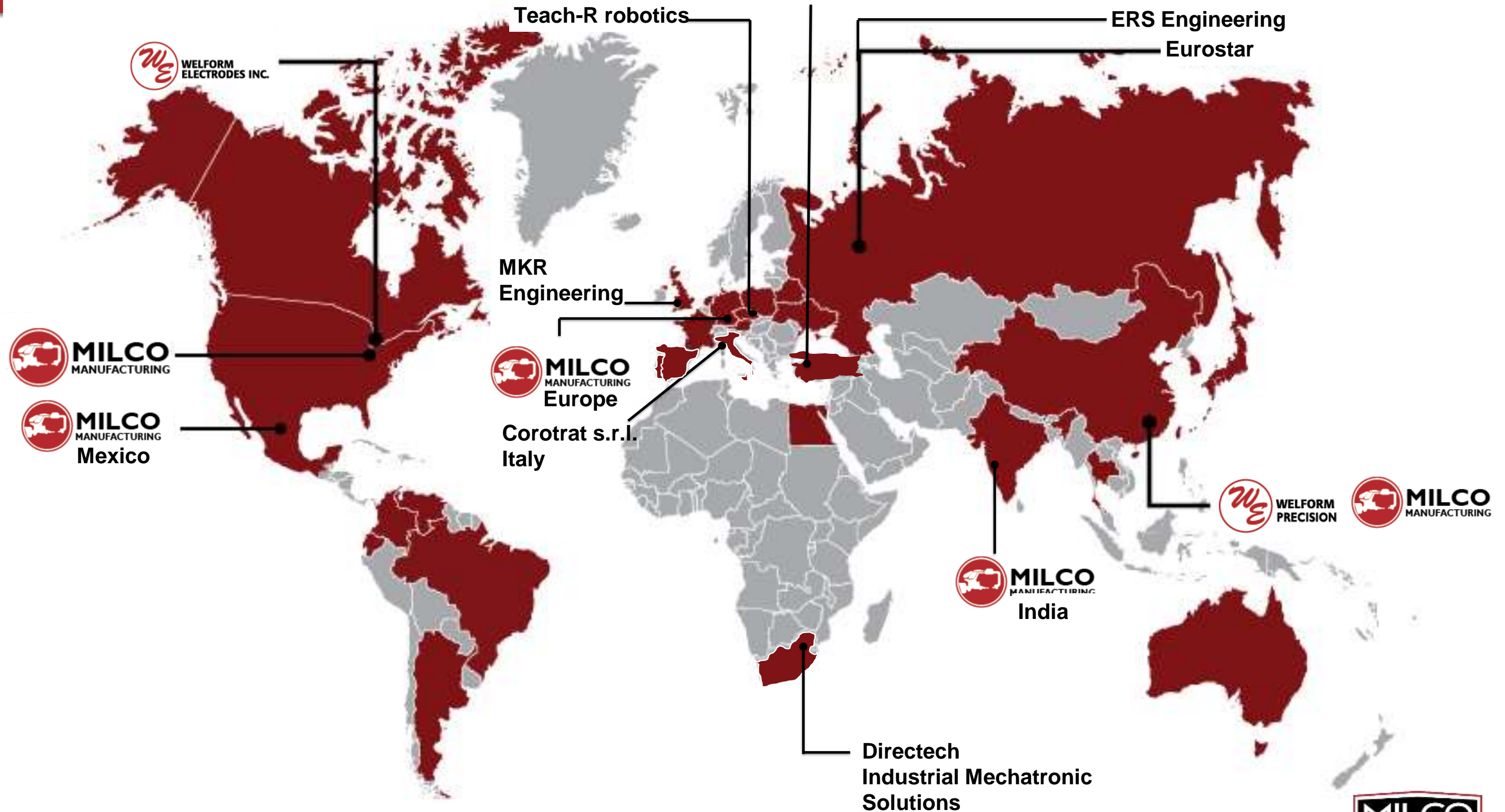

MILCO
INTERNATIONAL

Customers OEM & Tier



Customer Integrators



MILCO MODULAR GUN SYSTEM

A welding system made to fit your process...

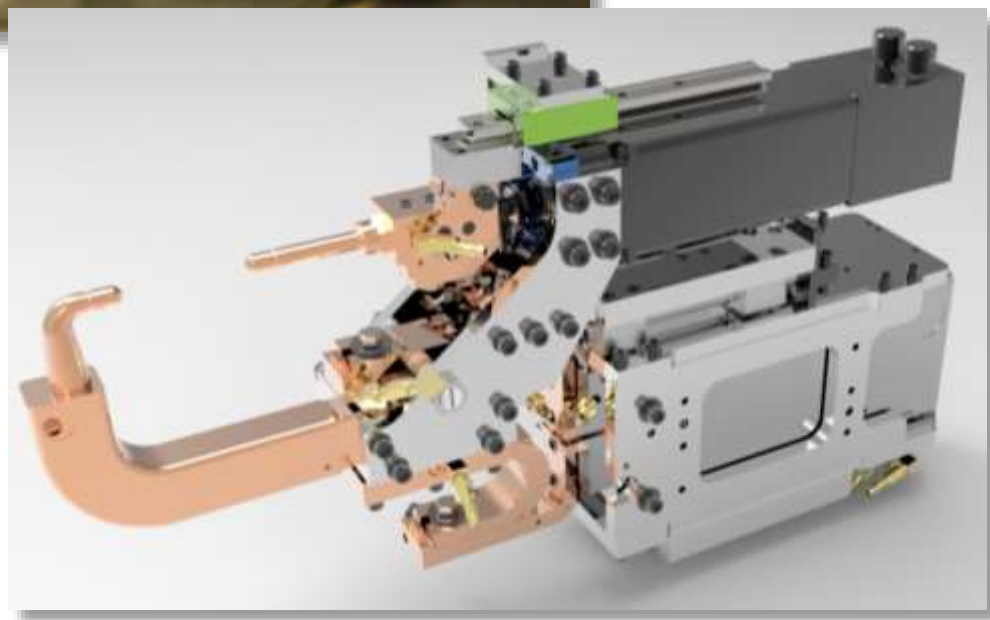

Milco Modular Gun Systems

- Milco Standard (Servo/Air)
- XR – Servo Gun (Servo)
- Delta - Aluminum (Servo)
- MLS - Lightweight (Servo)
- Titan – X Large throat
- Projection - Nut/Stud weld

ENGINEERING CAPABILITIES

Parametric Modeler

- Allows for quick turnaround when new design is required
- Can control options to reduce holders and adaptors used
- Creates shared components
- Reduces engineering cost

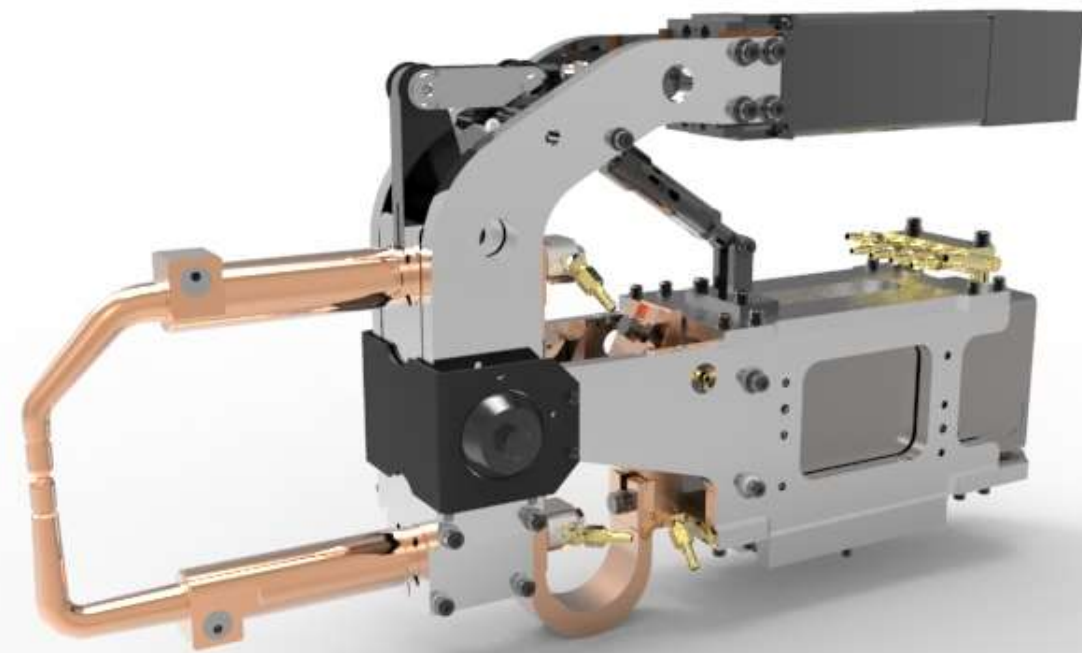
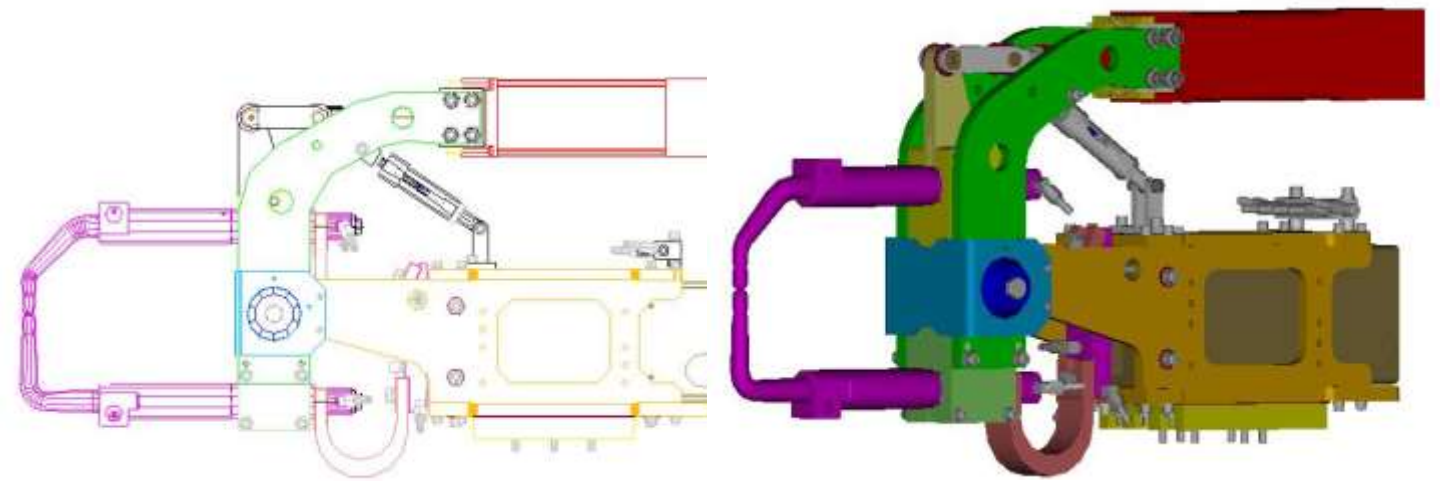

ENGINEERING CAPABILITIES

Customer Portal

- Maintenance Manuals

- Secure login

- Machine ledgers

- Design library

- Customer drawing access

The screenshot displays the Milco Manufacturing Customer Portal interface. The top navigation bar includes the Milco logo, a search bar, and user profile options. A left sidebar lists various categories: Design, Gun Library, Honda, Magna, Milco Presentations, Public Info, Test Sheets, Tony Teachworth, and Tower Automotive. The main content area shows a file browser with a table of files:

Name	Size	Date Modified
Design		2017/11/27 01:01 PM
Gun Library		2017/07/13 04:29 PM
Honda		2018/02/07 12:57 PM

Below the file browser, a technical drawing titled "MACHINE LEDGER - Professional Maintenance Machine Diagram - Section and Subassembly Diagram" is displayed. The drawing shows a detailed view of a machine component with various parts labeled. A "DOWNLOAD" button is visible next to the drawing. The right sidebar contains "File Tasks" (Download File, Open or Print PDF, View Version History, Delete File, View Properties, Send Link to File, Get Link to File, Move / Copy) and "File Info" (Size: 2 MB, Owner: John Pippin, Created: 12/15/2017 12:31 PM, Modified: 7/13/2017 4:47 PM, Path: Milco/Public Info/Milco Machine Ledgers).

MILCO MODULAR GUN SYSTEM

Maintenance Support Machine Ledgers

665-12000-119

286-10072-17	Link Assembly	480-10251-16	Servo Actuator
488-13696-06	Movable Arm	370-11748	Compensator
484-30589-01	Mov. Cap Adaptor	370-11775	Water Manifold Assembly
WB-26-312	Weld Caps	494-10574-30	Shunt Movable
484-30589-01	Stationary Cap Adaptor	TDC-5610	Transformer
488-13696-06	Stationary Arm	352-11012	Fulcrum Assembly
		494-10574-34	Shunt Stationary

Milco Machine Ledgers

- Complete System
- Tailored to Customers need

665-12000-119

665-14007-02

665-13000-06

Part Number	Description	Material	Notes
286-10072-17	Link Assembly	480-10251-16	Servo Actuator
488-13696-06	Movable Arm	370-11748	Compensator
484-30589-01	Mov. Cap Adaptor	370-11775	Water Manifold Assembly
WB-26-312	Weld Caps	494-10574-30	Shunt Movable
484-30589-01	Stationary Cap Adaptor	TDC-5610	Transformer
488-13696-06	Stationary Arm	352-11012	Fulcrum Assembly
		494-10574-34	Shunt Stationary

MILCO MODULAR GUN SYSTEM

Maintenance support Machine Ledgers – “C” Gun

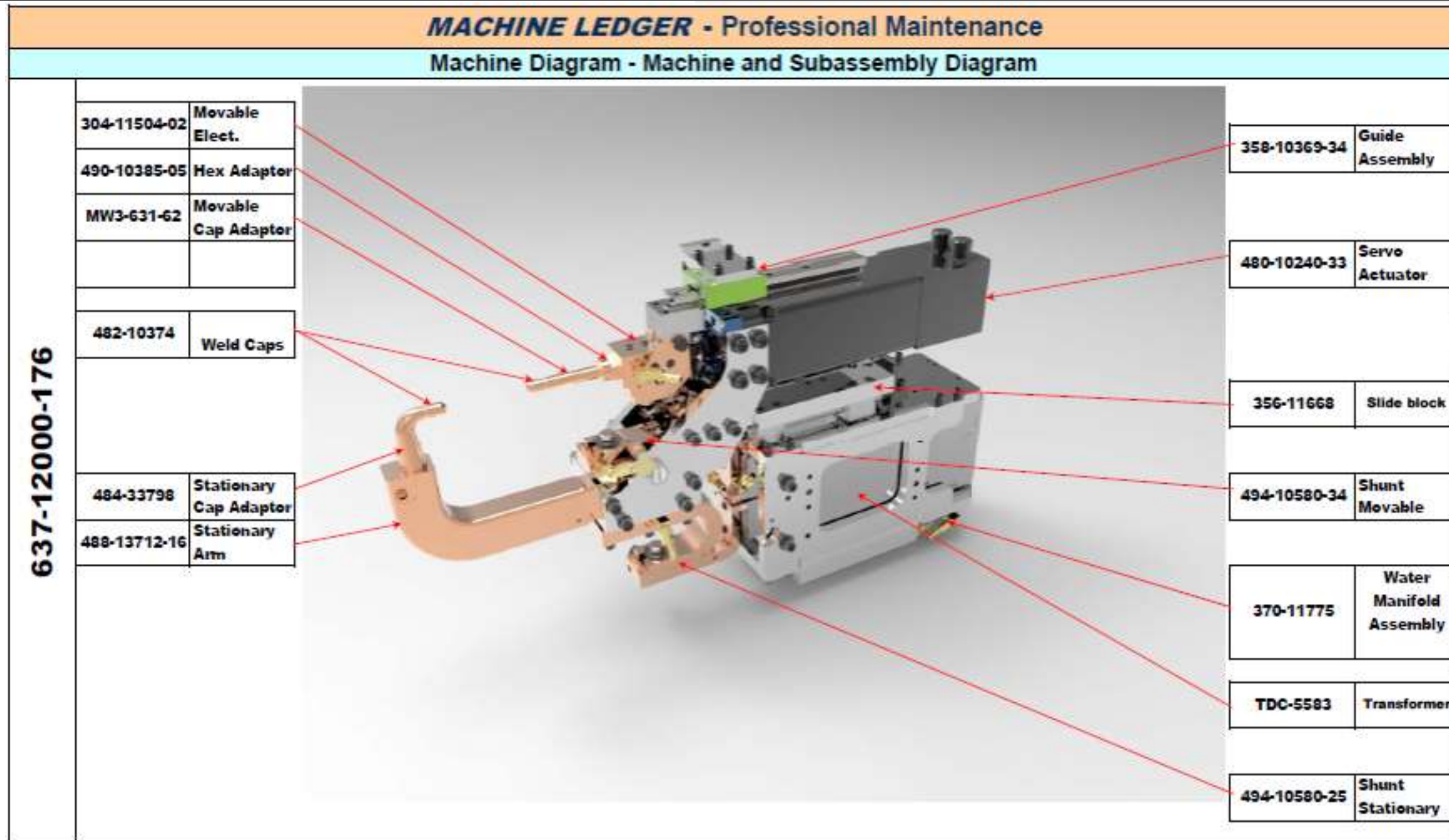

MILCO MODULAR GUN SYSTEM

SMP-Standard Maintenance Procedures

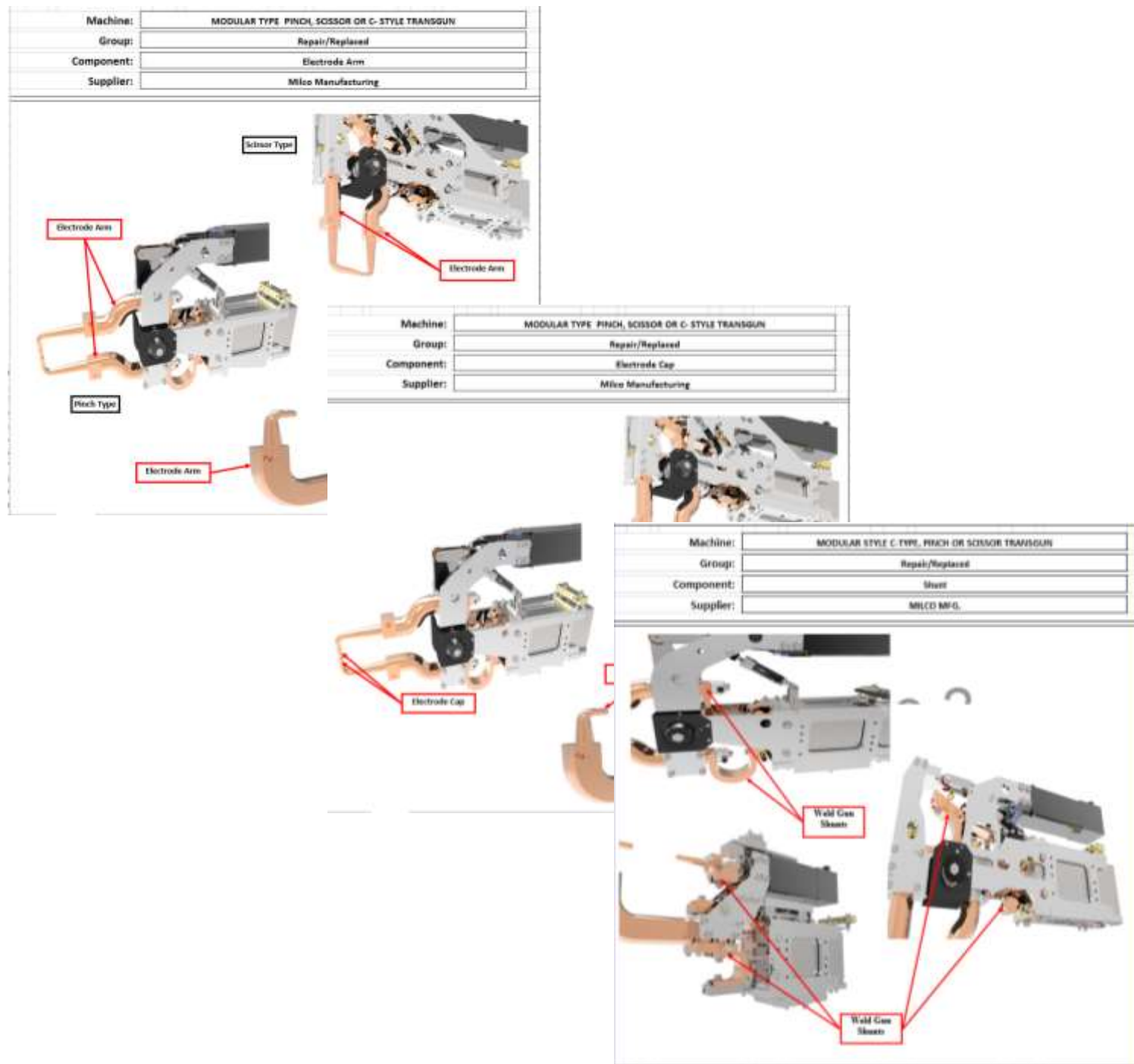

Standard Maintenance Procedures

- Electrode Arm Replacement
- Electrode Cap Replacement
- Shunt Replacement

MILCO MODULAR GUN SYSTEM

SMP-Standard Maintenance Procedures

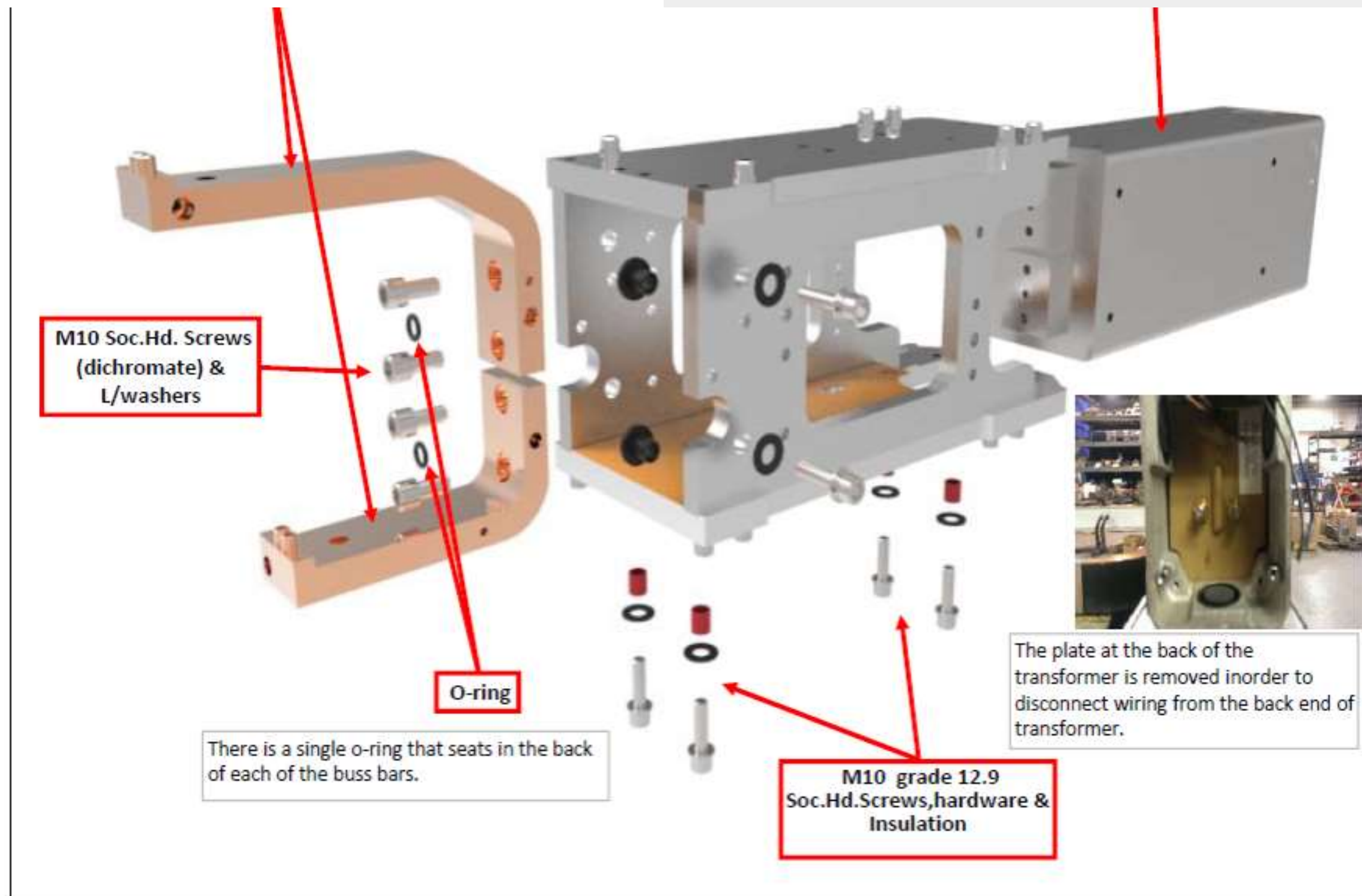

Aluminum Welding

Overview



- By 2025, nearly 27% of vehicle body and closures will be aluminum, a 20% increase over today.
- Consistency is of fundamental importance since aluminum's electrical and thermal conductivity requires 2.5 to 3 times the current, but only one-third the weld time of steel.
- Methods commonly used in steel that extend the cycle time in order to produce a weld are not effective for aluminum.
- The weld system must be able to deliver higher current levels in a time window 50 to 66% shorter than what is commonly employed for steel

Aluminum Welding

Considerations

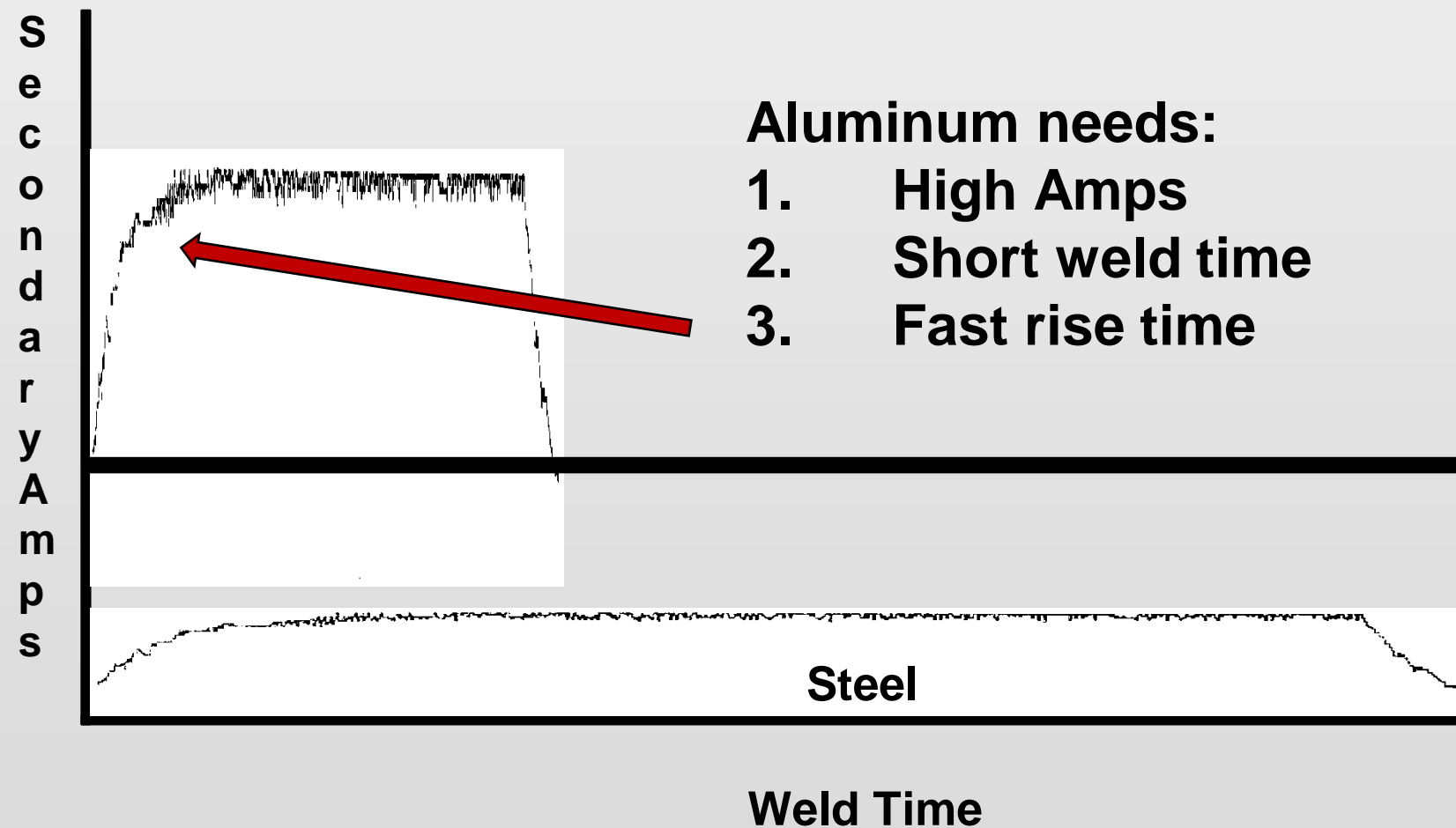
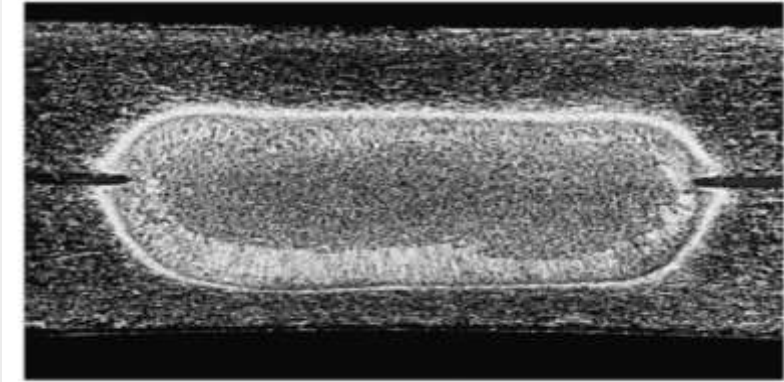

Aluminum Welding

Temperature Range of Plastic Condition

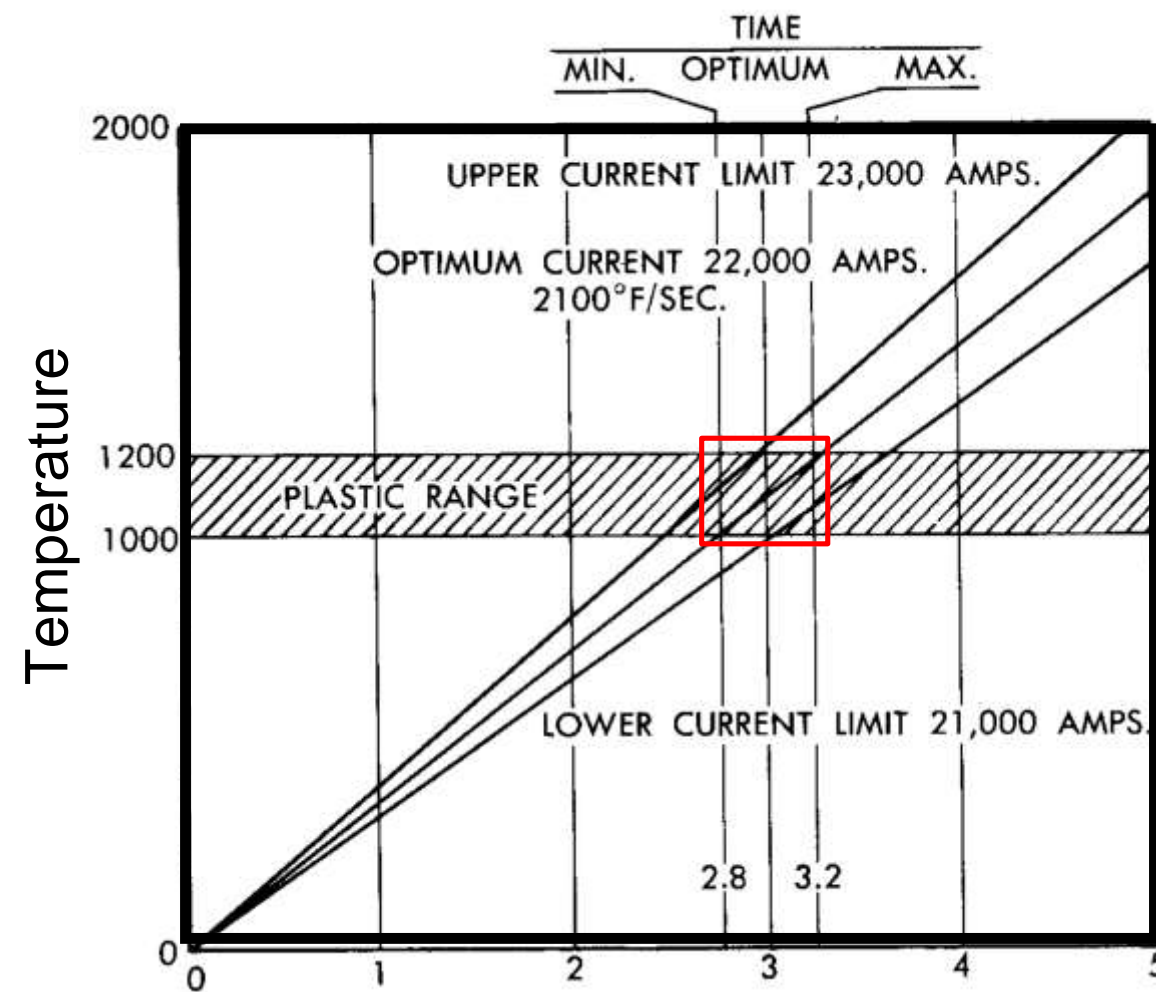

Aluminum

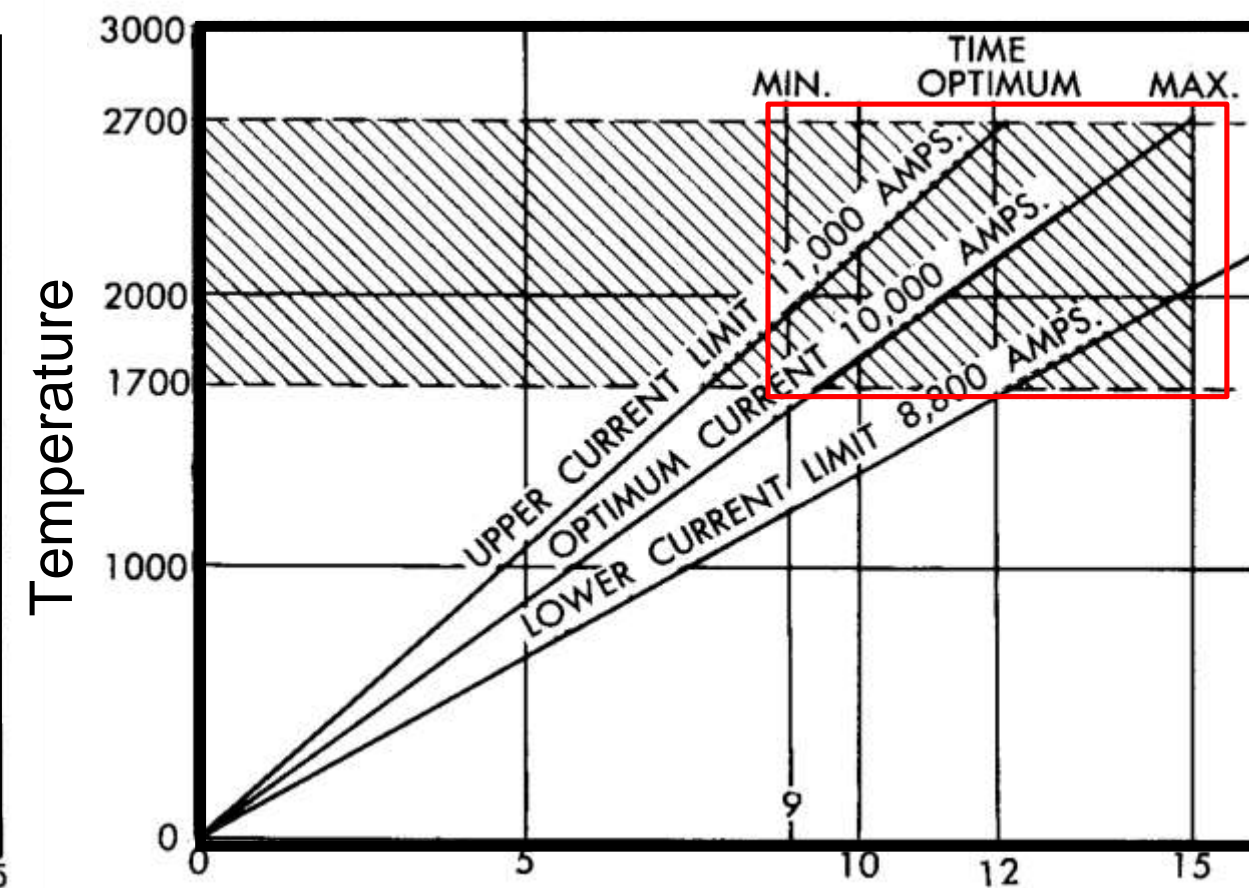

Steel

Weld Gun Considerations

Calculate ECTC of Gun

- Assure all current carrying components meet ECTC requirements. Larger cross sections required.
- Joules Law must be considered.
- $\text{Heat} = I \times I \times R \times T$ (2-3 times sec. current means exponential heat rise in secondary)
- Shunt, arms, shanks, etc.
- Avoid water-cooled cables

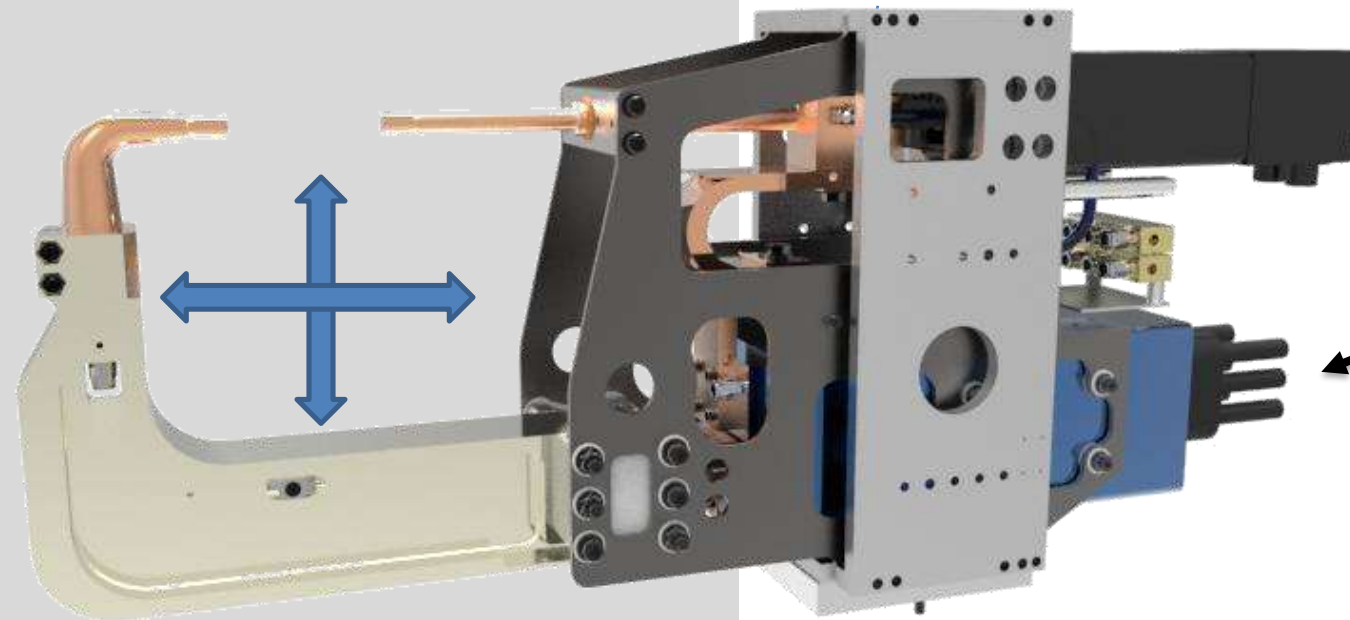

EMF Effects

- Higher secondary currents create higher EMF (Electro motive force)
- Consider EMF affects on servos, guides, slides, shunts, etc.
- Bolt down (reinforce) shunt adapters to avoid transformer secondary pad damage

*NOTE – size of the primary conductors will be larger and need more clearance and a larger bend radius

Aluminum Welding

Considerations

- Must consider Robotic dress pack change to match application.

Facilities

- Water system-pumps, headers, filtration all need to be evaluated
- Weld bus considerations must be made. Primary currents 2-3 times more than AC process. Higher secondary welding current pulses put additional notches and harmonics in primary voltage

Caps

- Cap changing, polishing and cutting
- Radiuses from 1" to 3" are normal
- Cap alignment is critical

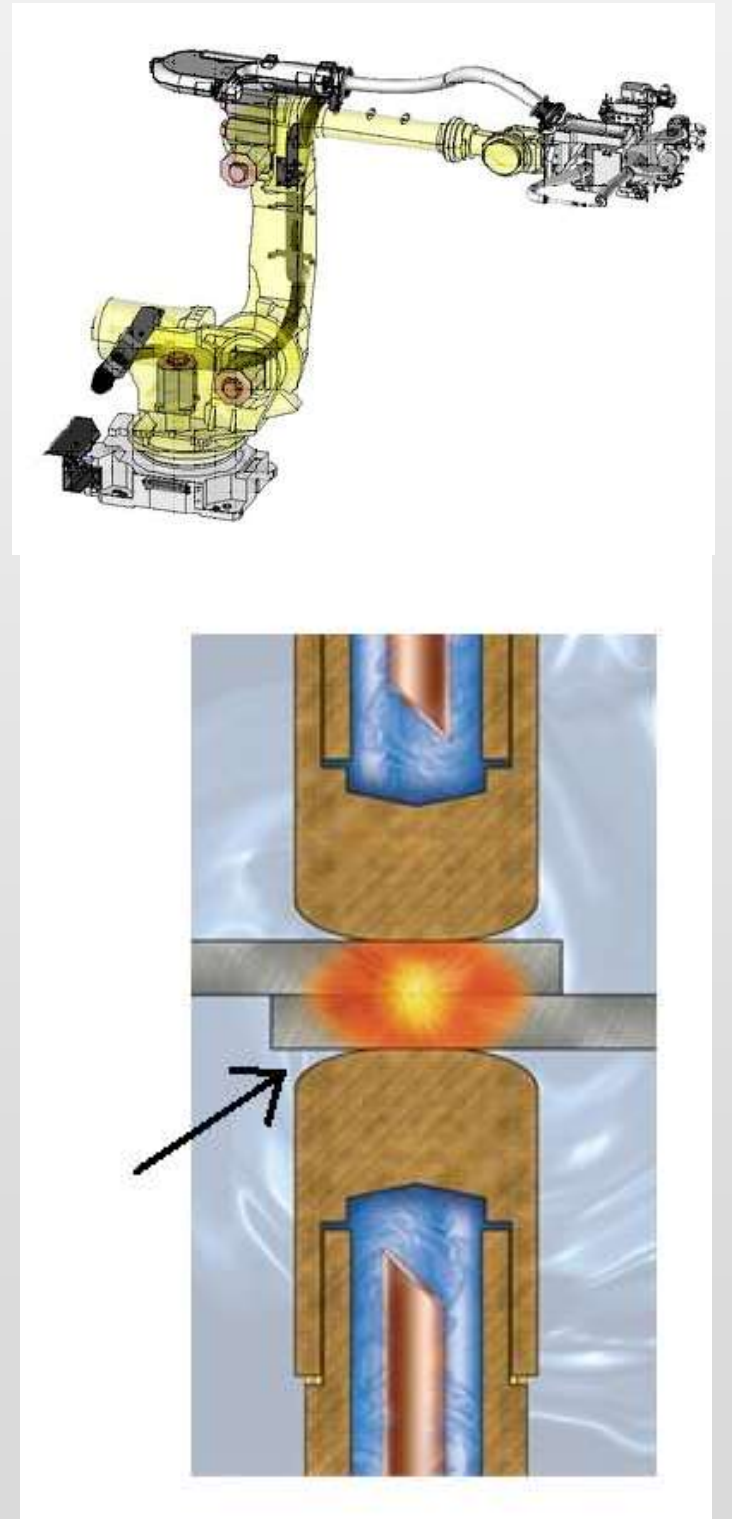

DELTA SERIES

Aluminum Welding Gun System

- Size 4 & 6 transformers
- Increased water flow
- Reinforced buss bar system
- Wider shunt for increased current flow
- Robust design reduces deflection
- “C” Gun with 3 point guide system
- Optional load cell available

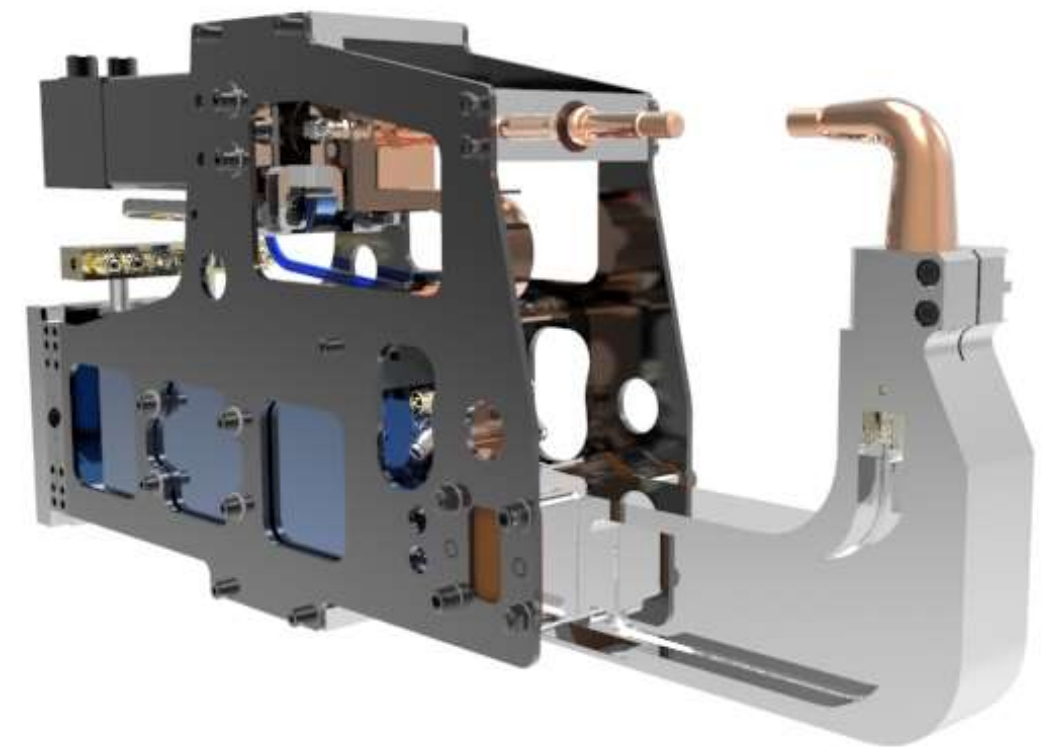
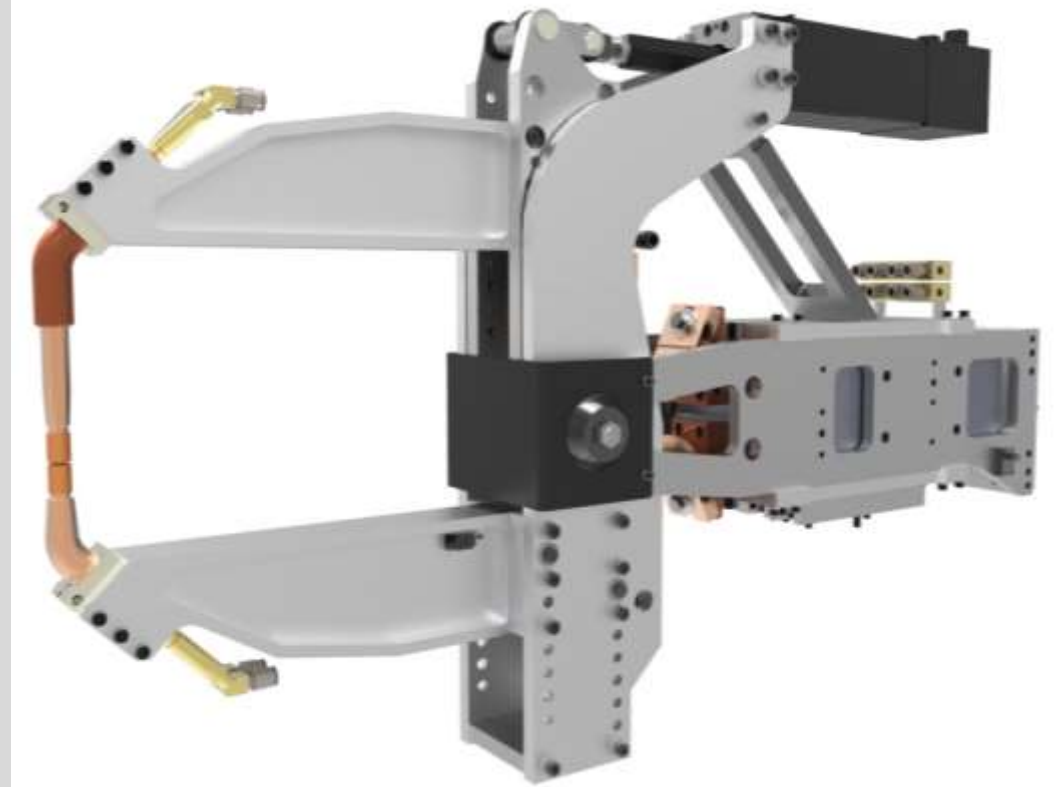

Aluminum Welding

Rivian Guns

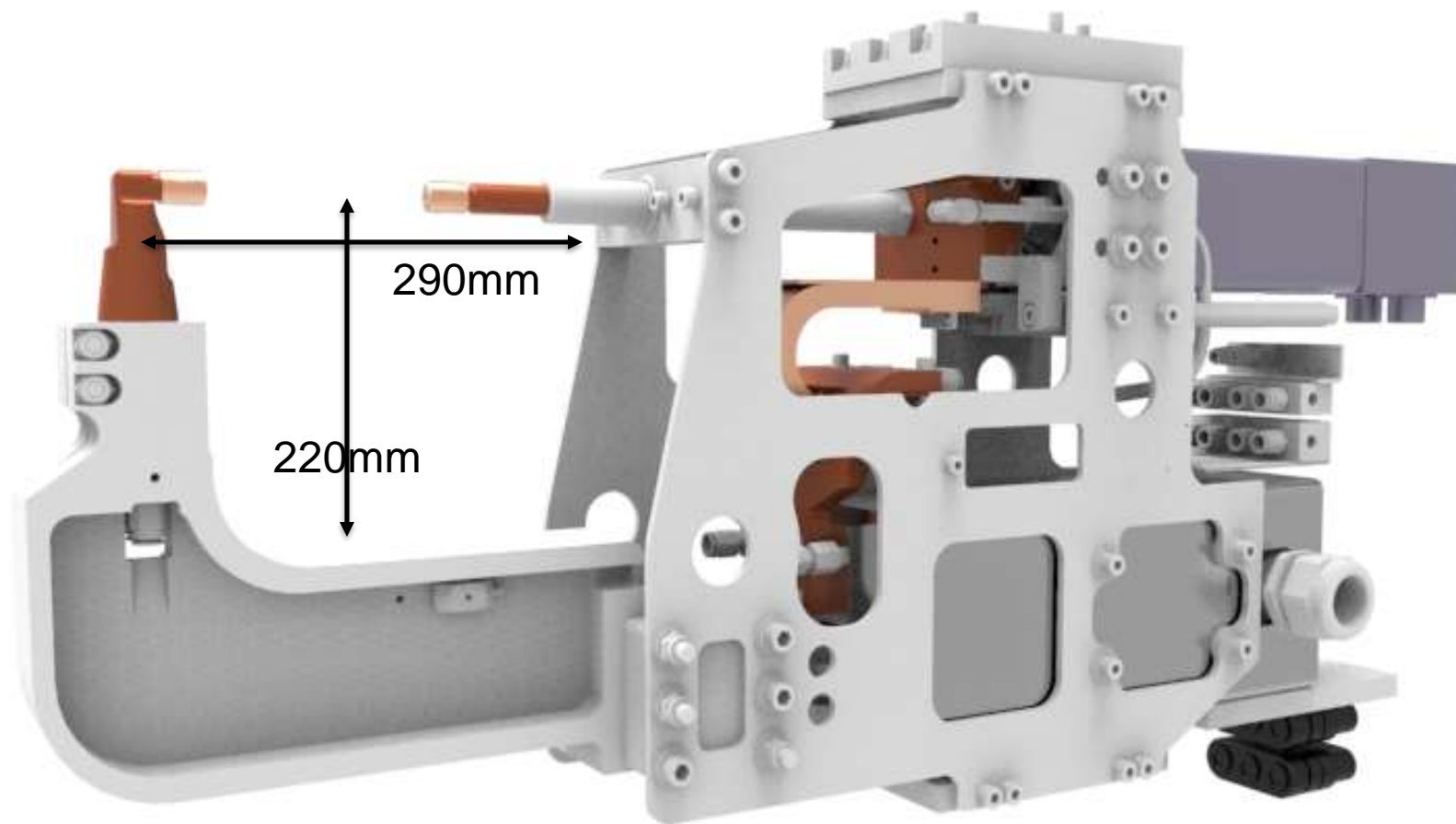

637-84000-102
120kg

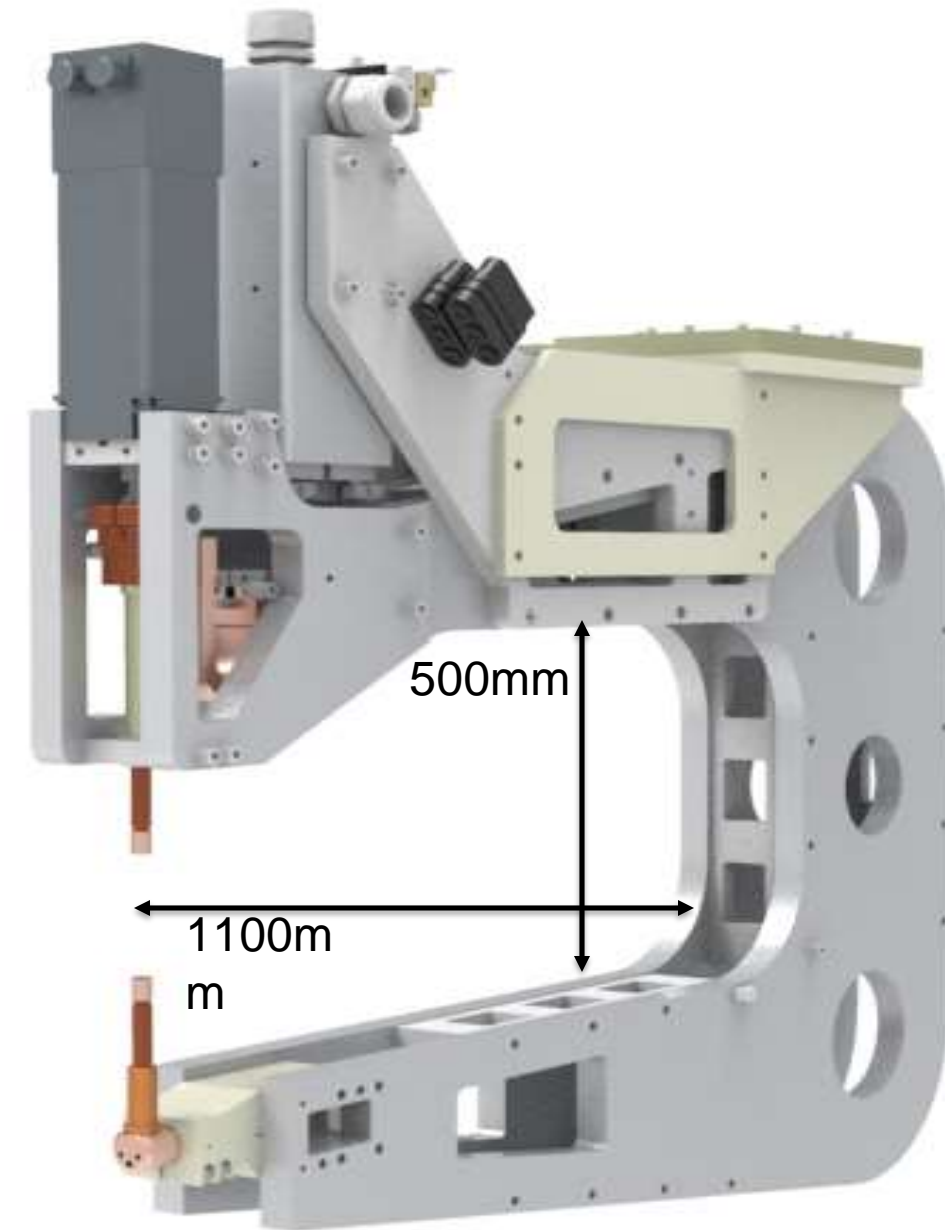

637-50000-20
345kg

Aluminum Welding

Rivian Guns

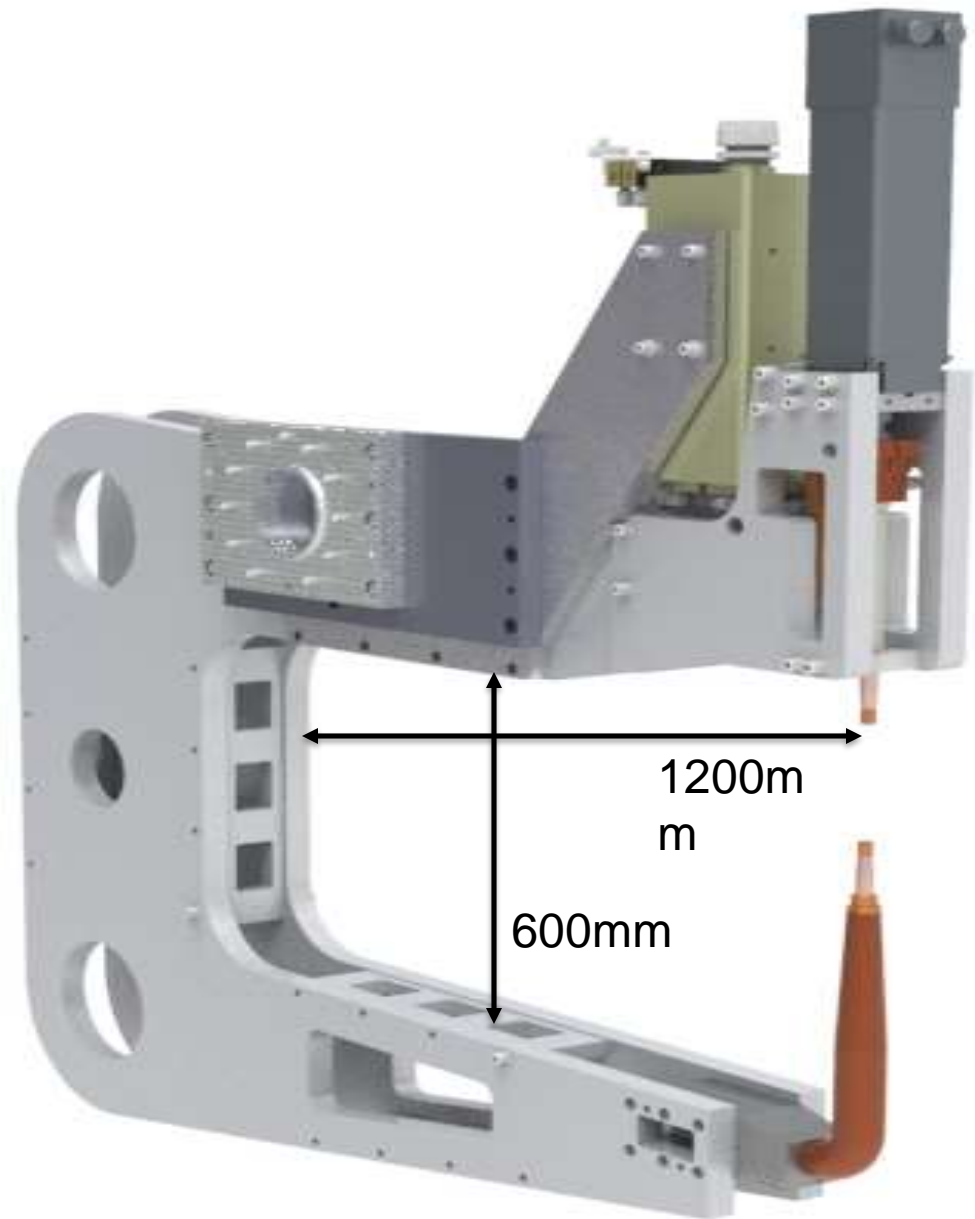

637-50000-34/35
384kg

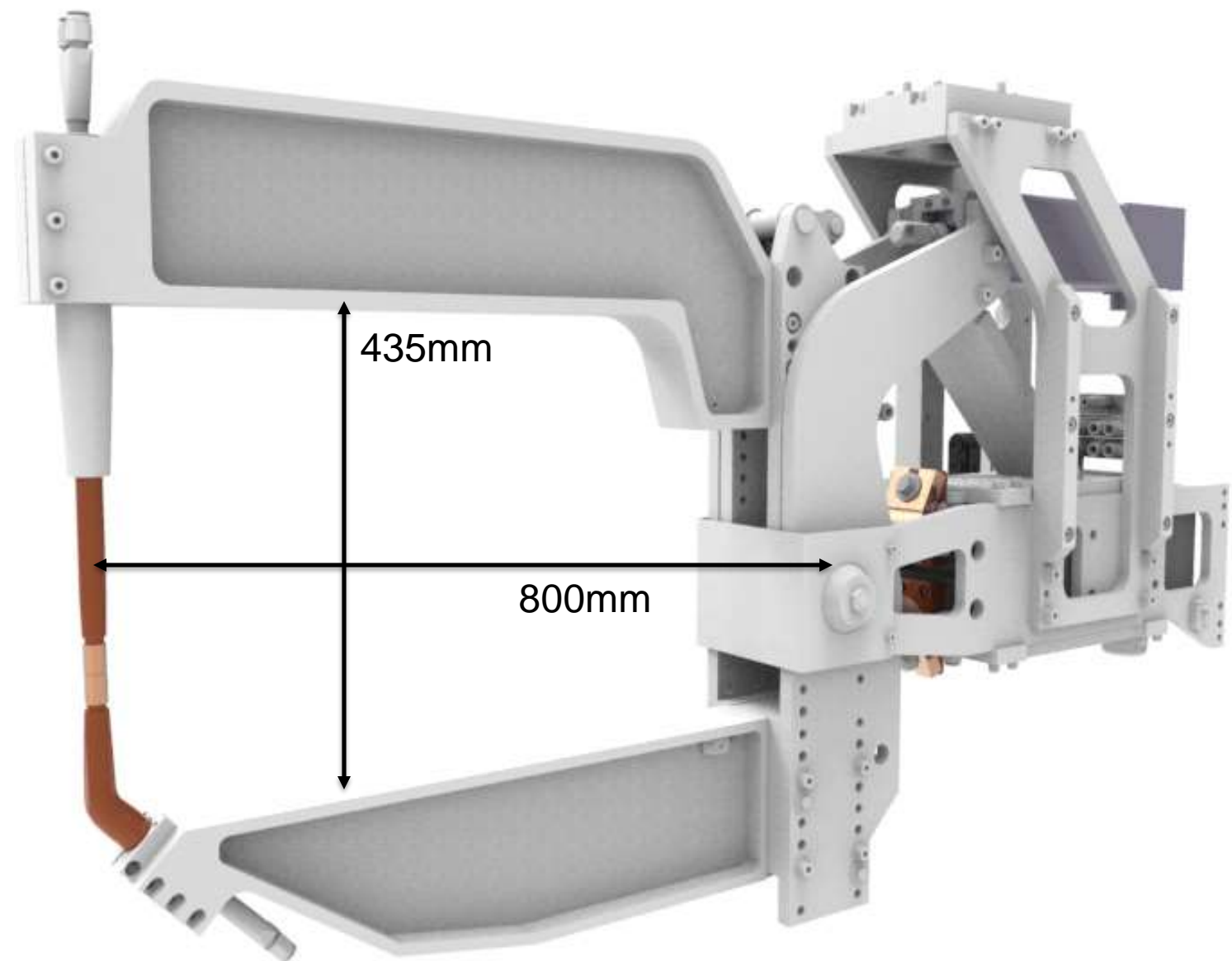

665-42000-19
175kg

SPECIALIZED MODULAR SYSTEMS

Delta Series

- Designed for Aluminum Welding
- High current and water flow

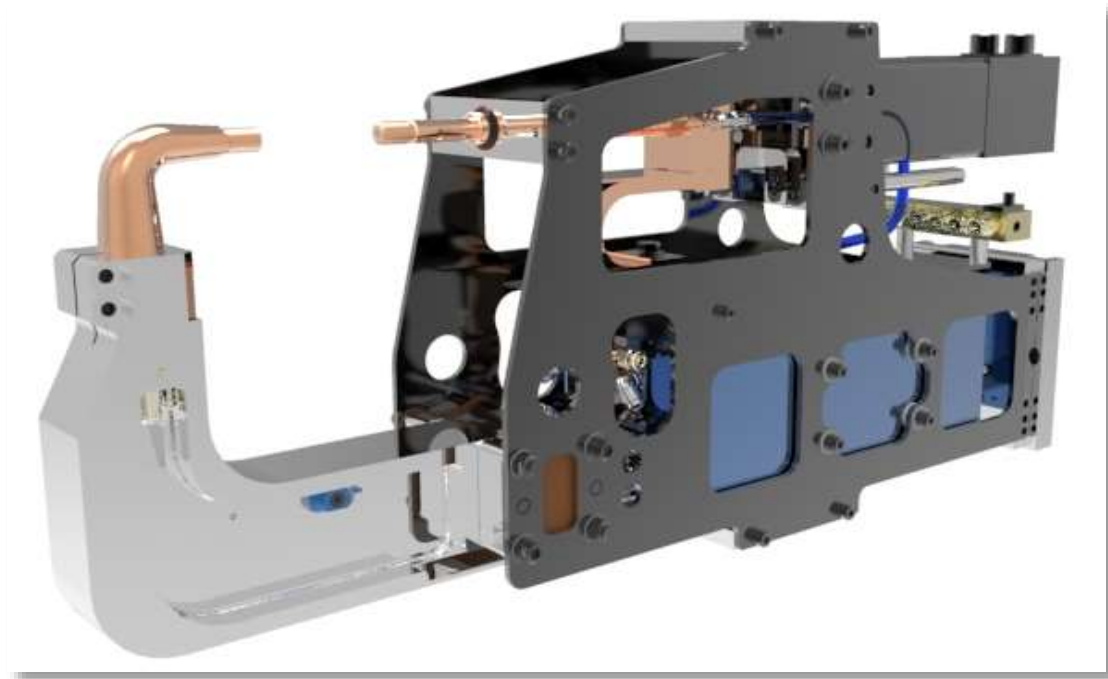

MLS Series Gen 2

- One Frame Pinch & "C"
- Under 70 kg up to 1800 lbs tip force



MLS Series Gen 2

COMPACT UNIVERSAL SERVO CHASSIS

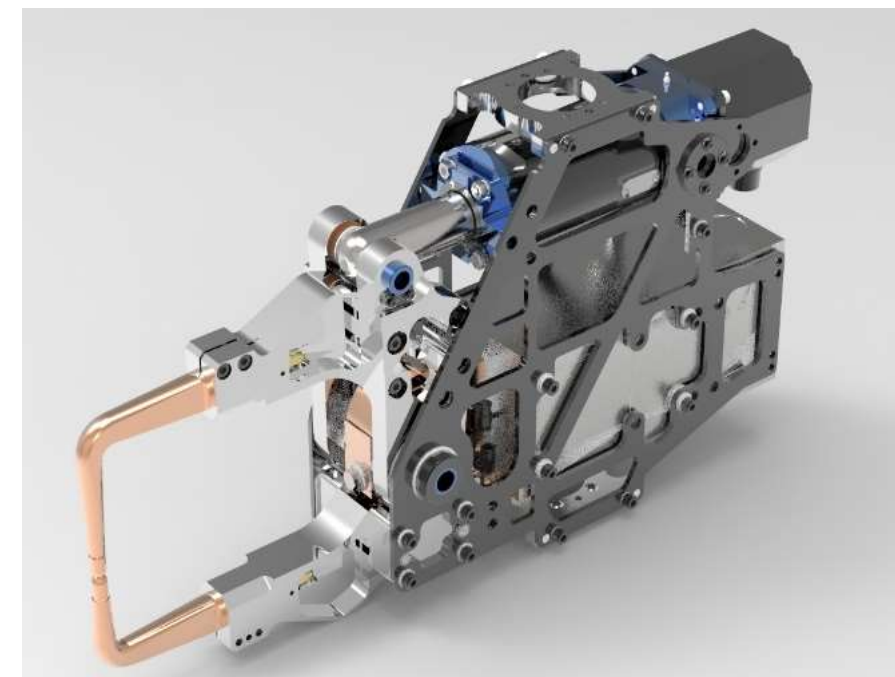
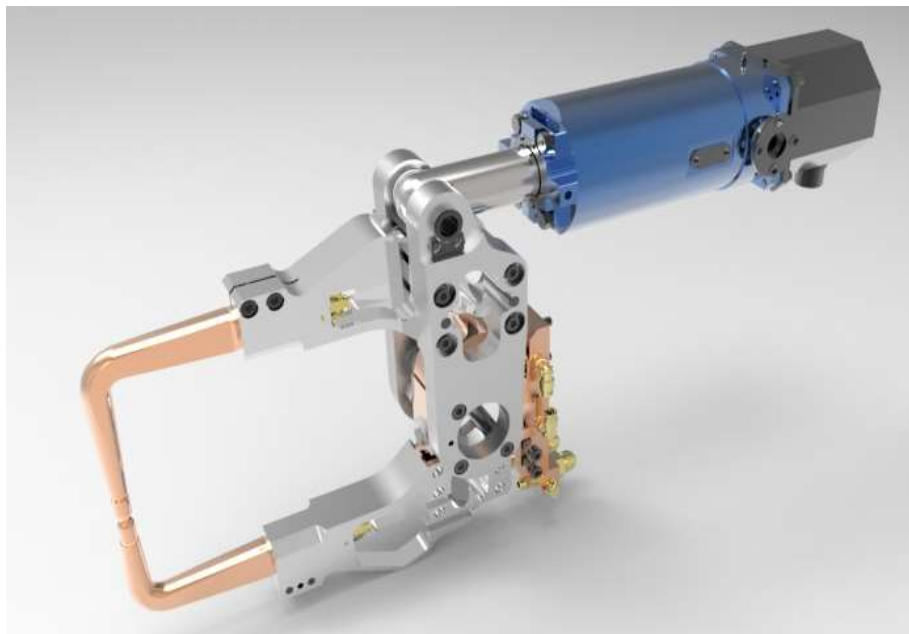
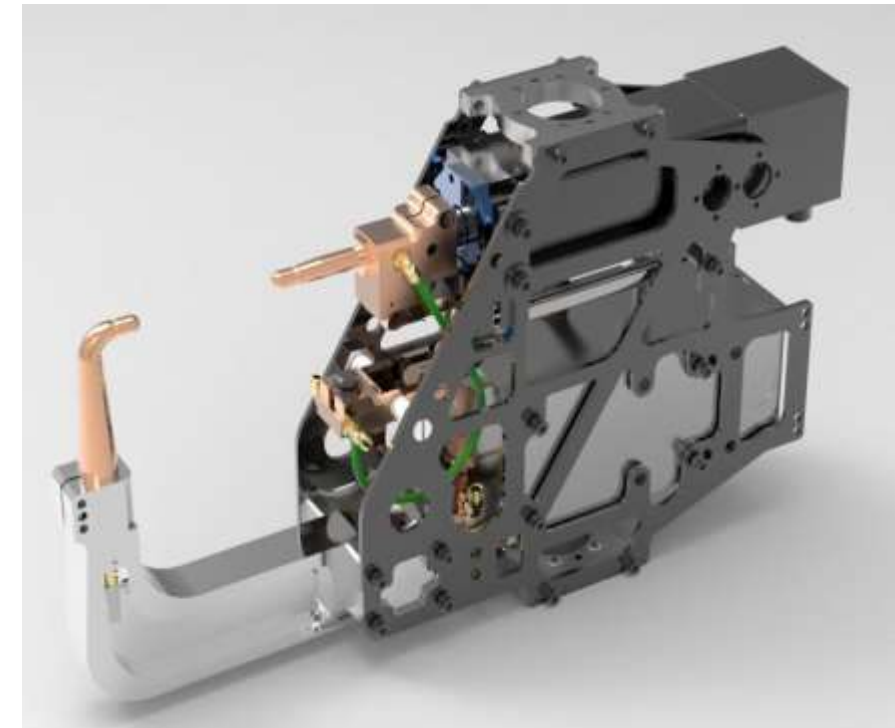
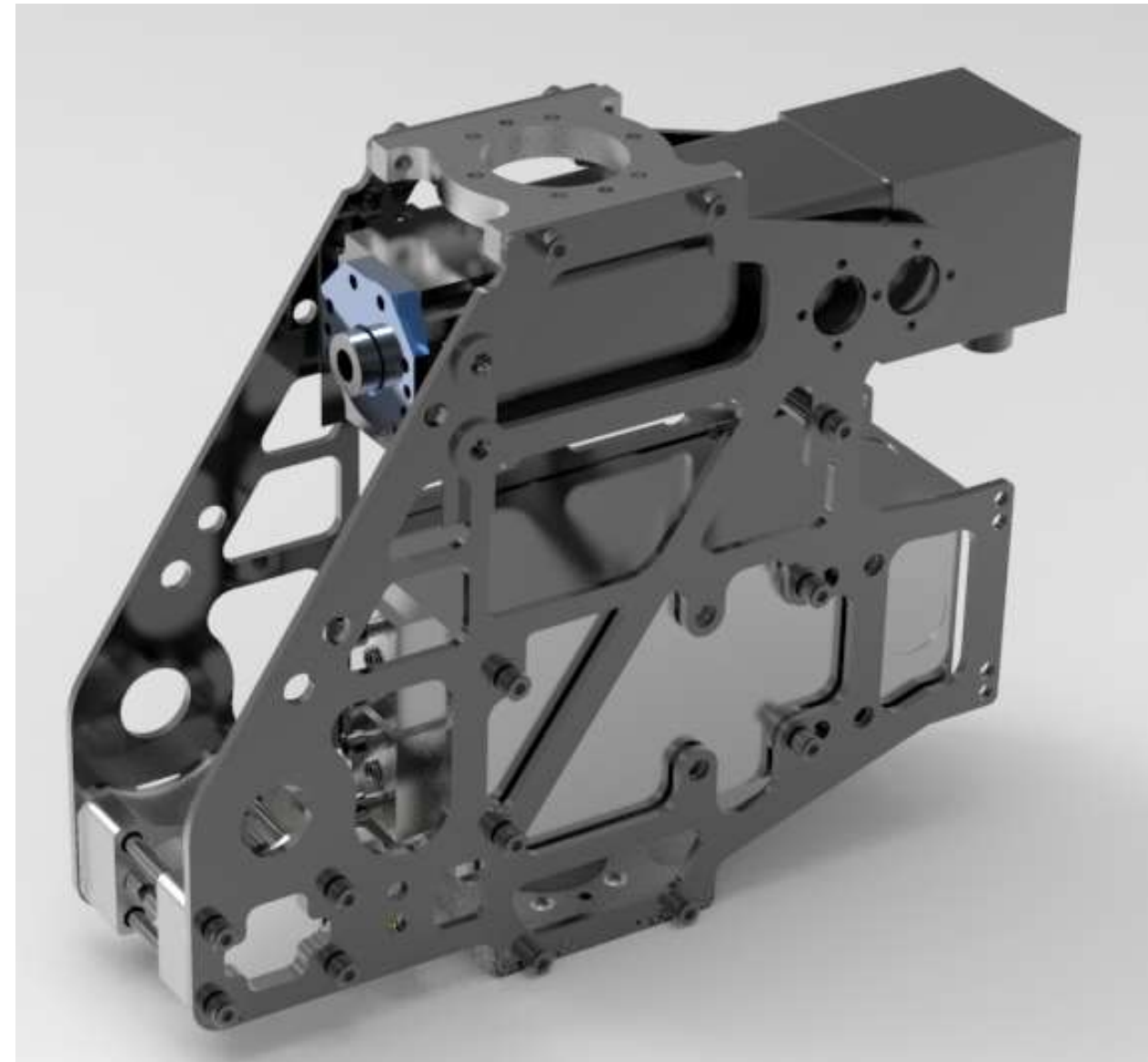
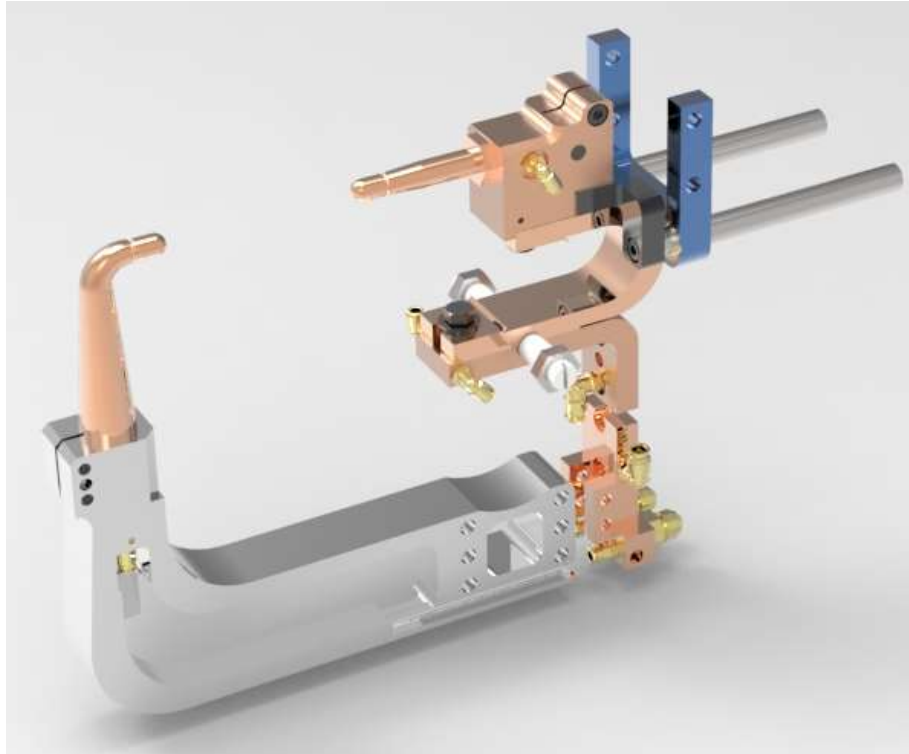

Servo Details

Flexible System

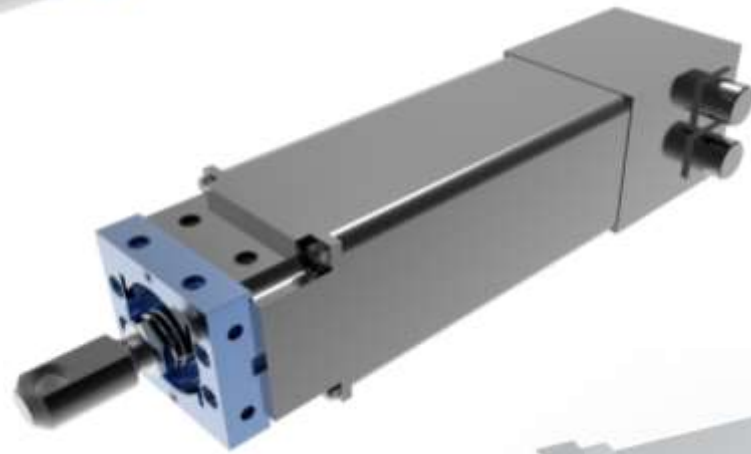

If more heavy duty cycles are required a water-cooled version of the servo actuator is available.

- Milco inline servo (ball screw) robot mfg. motor
- Tolomatic (roller screw) 3rd party motor robot feedback
- Exlar (roller screw) 3rd party motor robot feedback
- Diakont (roller screw)
- Fanuc, Yaskawa (Motoman), ABB, Nachi

KUKA

ABB

COMAU
ROBOTICS

FANUC

Kawasaki
Robotics

NACHI
NACHI ROBOTIC SYSTEMS INC.

MOTOMAN
YASKAWA CORP.

Rockwell
Automation

Rexroth
Bosch Group

MEDAR
A Division of WTC

EMERSON

MILCO MODULAR GUN SYSTEM

Pivot System

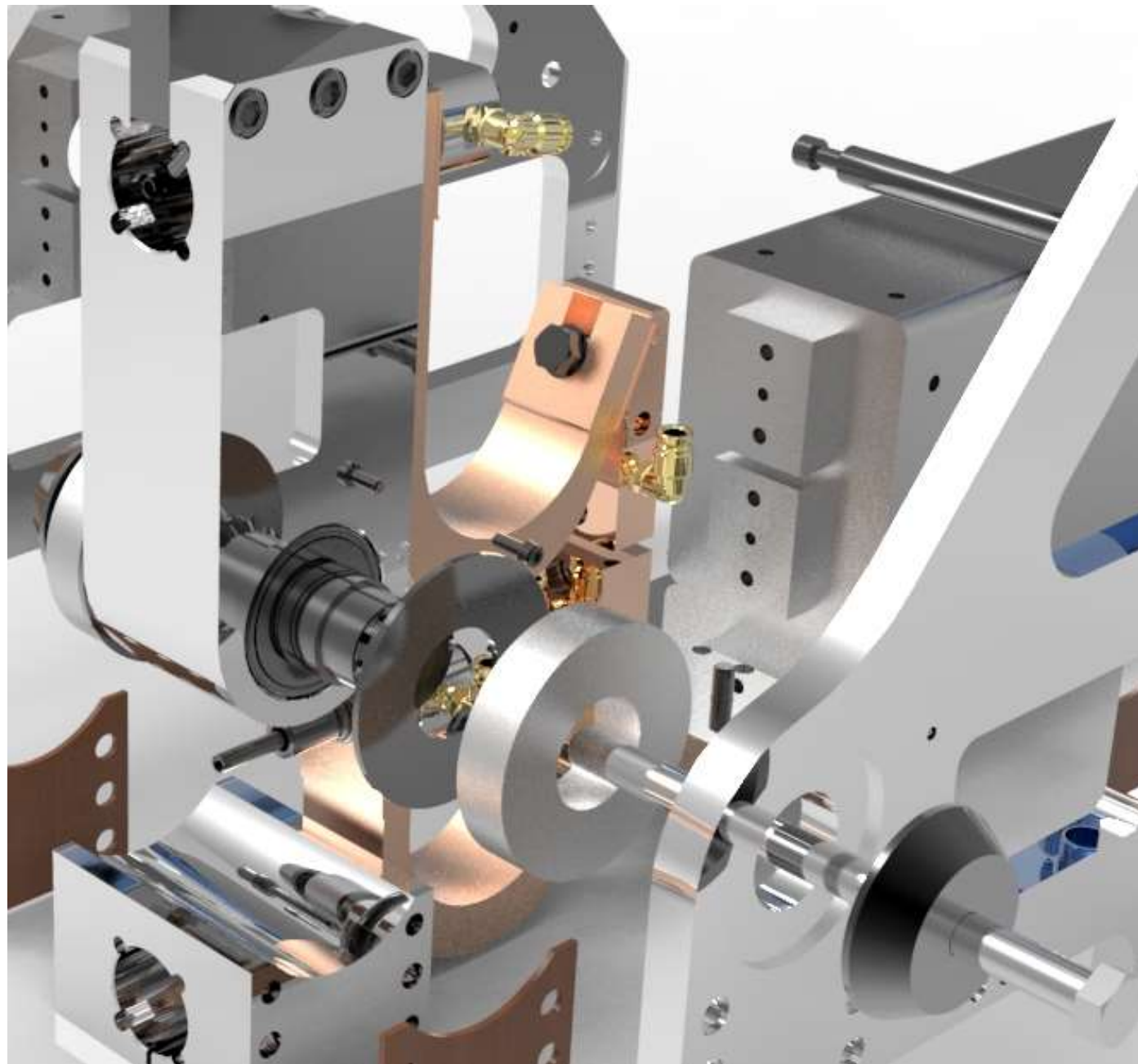

Milco modular gun systems

- Standard Pivot

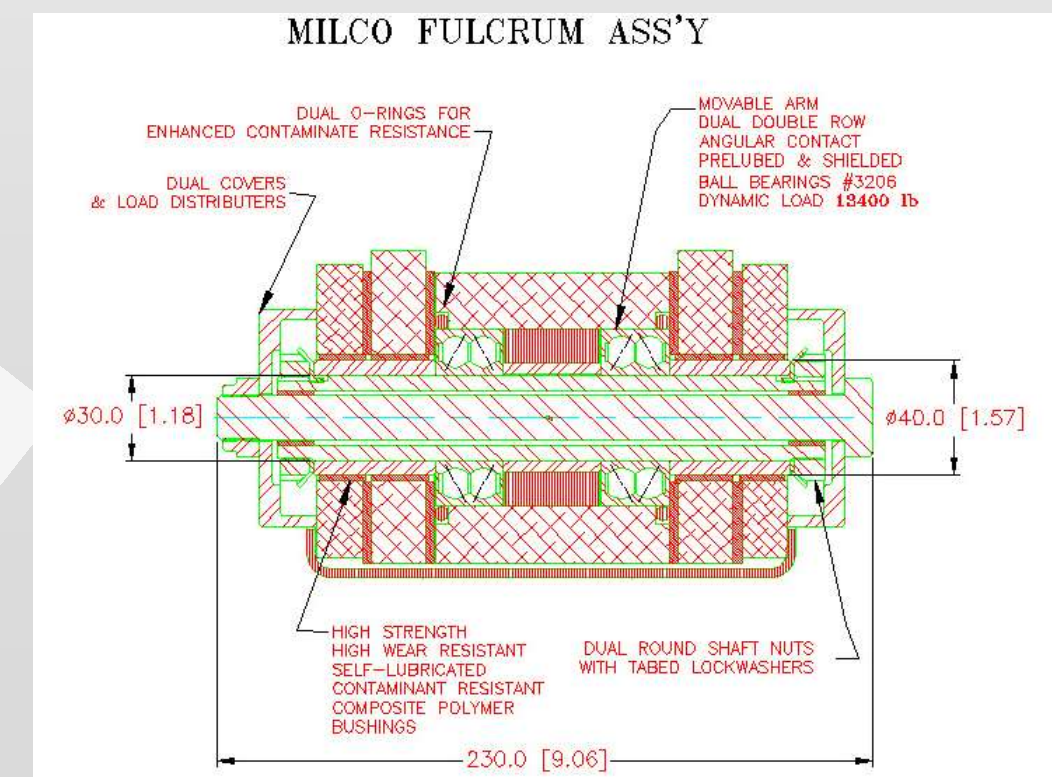

Aluminum Welding

Review

DO NOT use “steel guns” to weld aluminum

1. Insufficient H₂O flow to electrodes and transformer
2. Insufficient stiffness / robustness for long life and consistent weld quality
3. Shunts / Adapters are too small constant maintenance issues

Pay Attention to:

- Increased H₂O rate
- Correct electrodes “geometry consistent”
- Robust “stiff guns”, alignment is critical
- Consistent force
- Changes to robot dress-power, water layout
- High current / short time
- Plan for tip polishing, 2 to 3 times more than dressing, tip dressing to maintain profile and automated cap changing
- Consider plant power and water facilities
- Plan for 2 to 3 times maintenance
 1. Time
 2. Component replacement

New Technology

Rivet-Weld Technology

- Aluminum to steel, and boron steel welding
- Single sided welding

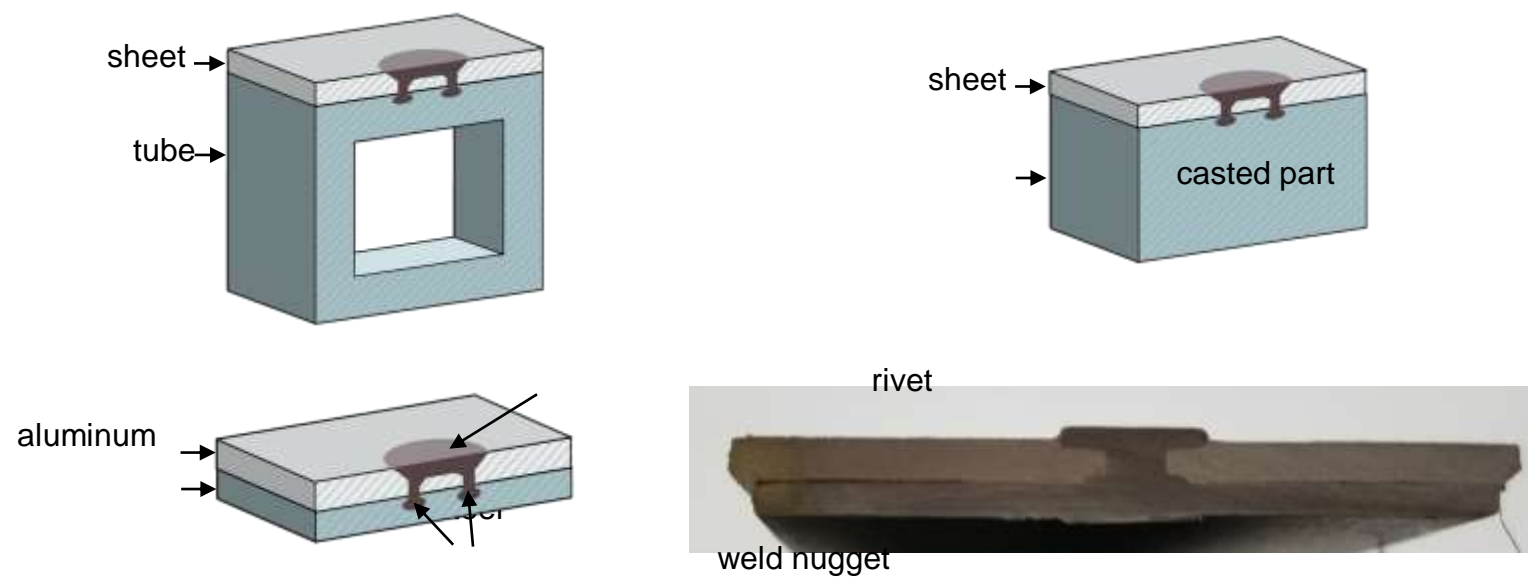

FSSW Friction Stir Spot Weld

- Aluminum and Titanium welding for Aerospace

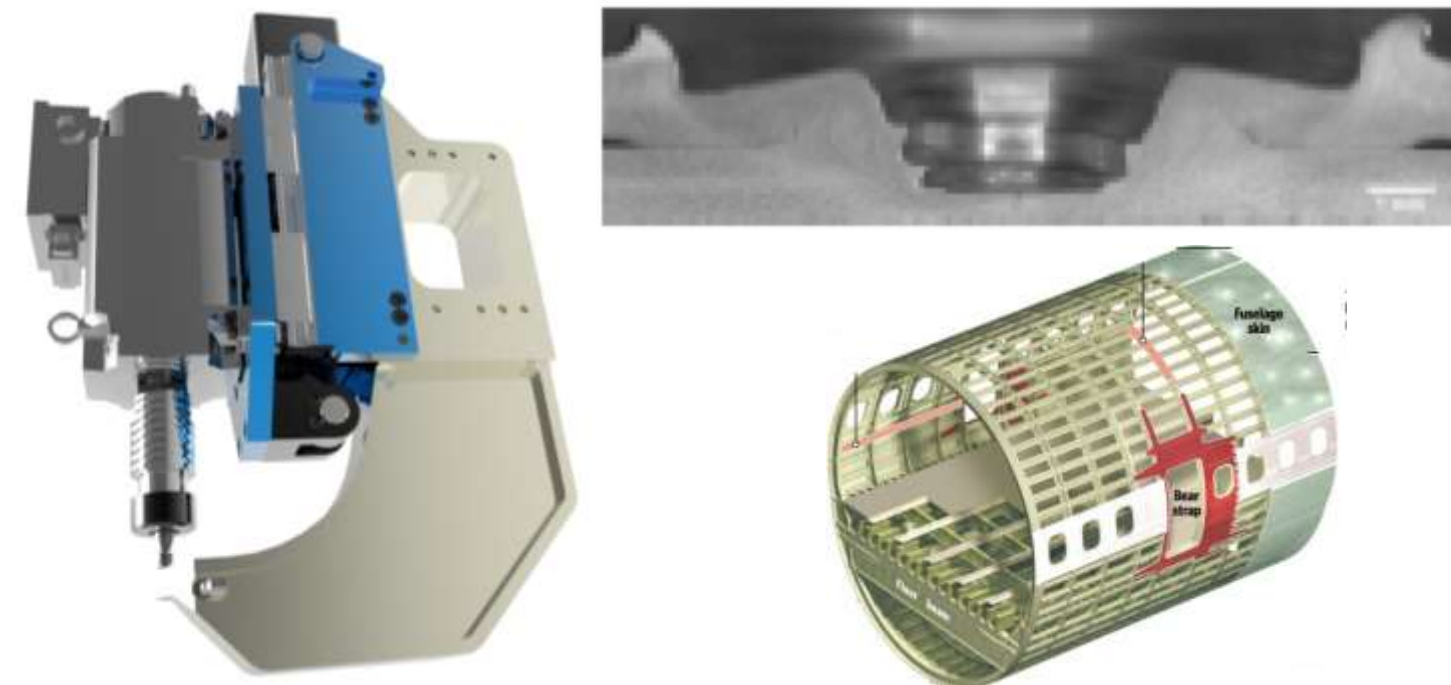

New Technology

Rivet-Weld Technology

- Aluminum to mild Steel

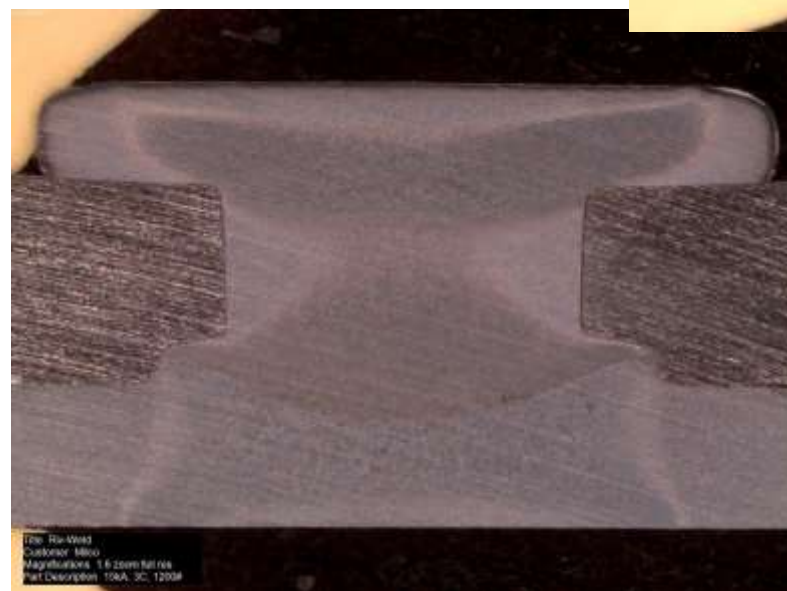
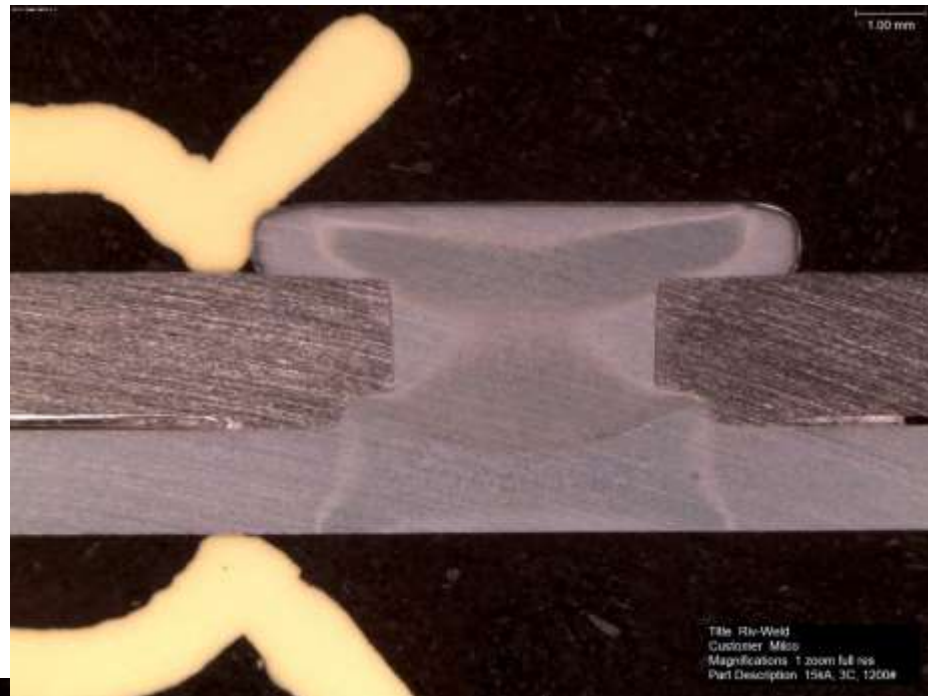

15k @ 3 cy

- Aluminum to Boron Steel

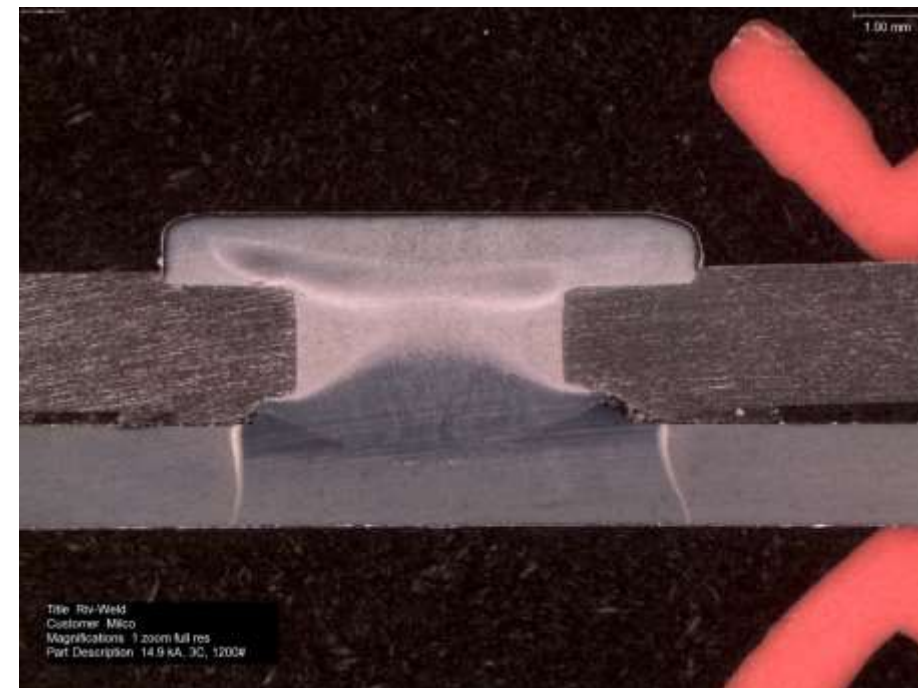

14.9k @ 3 cy

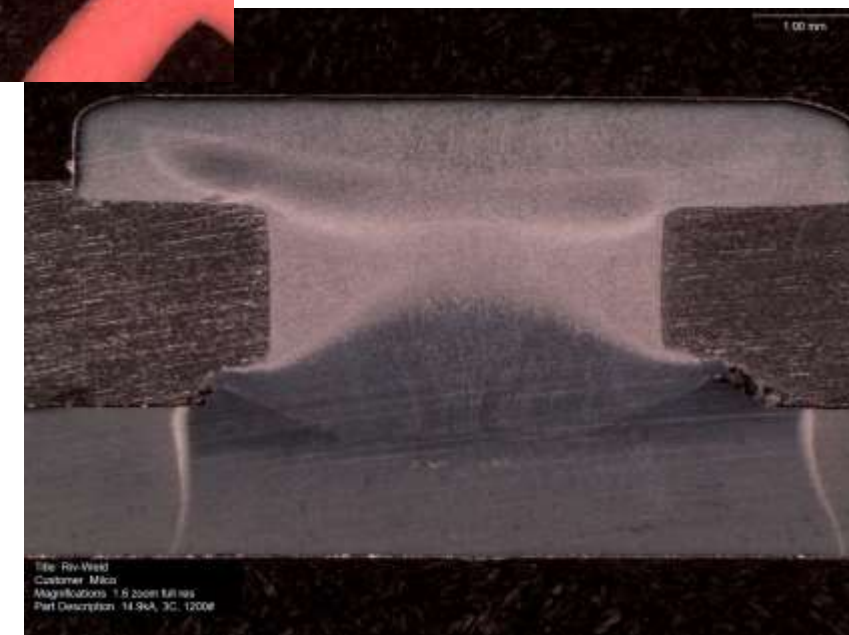

CONTACT

Main number: +1 586-755-7320

NORTH AMERICA

Jeff Beach

jbeach@milcomfg.com

John Pippin

jrpippin@milcomfg.com

ASIA PACIFIC

BK Ooi

bk.ooi@welform.cn

EMEIA

Martin Smith

msmith@milcomfg.com

EUROPEAN

Paolo Gai

paolo.gai@corotrat.it

TURKEY

DSC Mekatronik

info@dsc.com.tr

The logo for MILCO International. It features the word "MILCO" in a bold, white, sans-serif font, centered within a black rectangular field. This field is enclosed by a white border, which is further surrounded by a red, slightly irregular border. The entire logo is set against a white background.

MILCO

I N T E R N A T I O N A L